

OPL25N

Low-level Order picker

OPL25N is a low-level order picker that has strong power and better stability when increasing or decreasing speed thanks to the German AC drive and Italian Controller. Plus its electric steering system and German REMA multi-functional handle make it has high working efficiency and driving comfort.

4 point structure floating shock absorption platform and rubber pads minimize the vibration. The ergonomically curved backrest can efficiently avoid driver's fatigue; Sideways battery design allows quick and easy replacement in multi shifts working.

Fully upgraded features make picking easier and more efficient and it provides various optional configurations such as extension bracket, caution light, blue light, entry rollers, storage tray, double USB charging port. etc.



NOBLELIFT
Material Handling

We promise, We deliver

OPL25N
Low-level Order picker



NOBLELIFT CANADA

850 RUE ELLINGHAM
POINTE-CLAIRE
QUEBEC, CANADA H9R2S4

TEL: (514) 697-0117
EMAIL: INFO@NOBLELIFTCA.COM
NOBLELIFTCANADA.COM

NEW *Noblilift Products*
ARRIVAL

ISO9001 / ISO14001

//2020.06

NOBLELIFT INTELLIGENT EQUIPMENT CO., LTD

www.noblilift.com

OPL25N Highlights



Display whole truck condition information via control instrument and multifunctional handle

German REMA multifunctional handle
Reliable and ergonomically designed REMA handle each button can be easily reached and controlled, which makes driving more comfortable.

The multifunctional control instrument can display truck conditions, battery capacity, working time, travel speed, and steering angle. When something goes wrong, the outer ring light of the instrument will turn to red from blue.

USB charging port
Double USB charging port power up more equipment.

The standard pin code switch can set multiply start passwords, the ID card is also supported to start the truck.

Robust and durable structure, high power and efficient driving technology

German AC drive technology
AC drive system performs perfectly thanks to its high power maintenance-free Geman Schabmuller AC drive motor and KORDEL gearbox while smoothly increasing or decreasing speed.

Italian ZAPI Controller
Provide clients with reliable, flexible and high-performance control system solution as adopting Italian ZAPI drive controller.

High power and performance pump
Make lift easier and efficient by using high power and performance pump.

German load wheel has a long service life but a lower cost.

The reinforced welded fork is more robust and durable. Adopting adjustable trolley design in lifting that makes height adjustment and maintenance easier and convenient.

German drive wheel ring has a long service life, high load, and is not easy to wear.

Well-designed and easy to maintain

Sideways battery exchange compartment plus adjustable handling bracket makes battery replacement easier and quicker.

A variety of extension supports are available to meet the installation requirements of different extension equipment, such as WMS display, barcode scanner, storage tray, file plywood, etc.

The upper adjustable balance wheel can realize the easy adjustment of the balance wheel.

Easier to entry Australian pallet with entry rollers.

The jog button on both sides of the truck allows the operator to operate truck forward/backward or lift the fork while walking beside. There is no need for the operator to get in and out of the truck frequently to operate it. That greatly improved the picking efficiency and operation safety by reducing the speed controlled by the jog button.

Safe and comfortable, easy storage

The standard blue light does not only automatically lit while the truck forwarding but also follows the handle to turn while the truck turns. It greatly improves the safety of the operation.

Safety flanks and non-slip surface materials on both sides of the backrest ensure the operator not to be thrown off while the truck turns at high speed. This design greatly improves the safety of driving. Meanwhile, the handle above the backrest provides a grasping point for the operator when get up or down the truck, provides superior comfort for the operator.

Large storage tray can be used for storing stretch film, art knife, marker pen, or other tools.

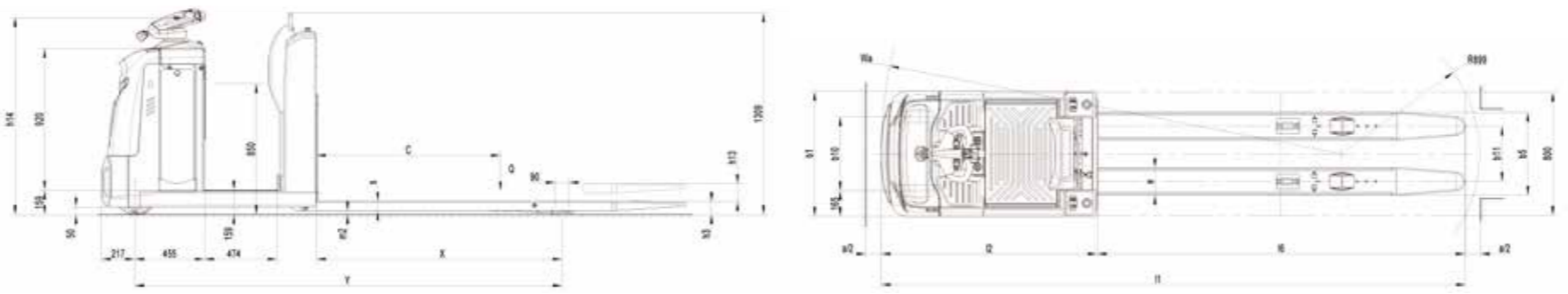

Type sheet for industrial truck acc. to VDI2198

Type sheet for industrial truck acc. to VDI2198			
Distinguishing mark			
1.2	Manufacturer's type designation		OPL25N
1.3	Drive		Battery
1.4	Operator type		Order-pucker
1.5	Load capacity/Rated load	Q (t)	2.5
1.6	Load center distance	c (mm)	1200
1.8	Load distance, the centre of drive axle to fork	x (mm)	1535 ¹⁾
1.9	Wheelbase	y (mm)	2723 ¹⁾
Weight			
2.1	Service weight	kg	968
2.2	Axle loading, laden front/rear	kg	1290 / 2530
2.3	Axle loading, unladen front/rear	kg	980 / 340
Tires, chassis			
3.1	Tires		Polyurethane(PU)
3.2	Tire size,front	Øxw (mm)	Ø 250×80
3.3	Tire size,rear	Øxw (mm)	Ø 82×82
3.4	Additional wheels(dimensions)	Øxw (mm)	Ø 180×80
3.5	Wheels,number front/rear(x=driven wheels)		1+1x/4
3.6	Tread,front	b10 (mm)	480
3.7	Tread,rear	b11 (mm)	360
Dimensions			
4.4	Lift	h3 (mm)	115
4.9	Height of tiller in drive position min./max.	h14 (mm)	1280
4.15	Height, lowered	h13 (mm)	85
4.19	Overall length	l1 (mm)	3770 ²⁾
4.20	Length to face of forks	l2 (mm)	1370 ²⁾
4.21	Overall width	b1 (mm)	810
4.22	Fork dimensions	s/e/l (mm)	60/ 180 / 2400
4.25	Width across forks	b5 (mm)	540
4.32	Ground clearance, centre of wheelbase	m2 (mm)	25
4.34	Aisle width for pallets 800 x1200 lengthways	Ast (mm)	3970 ^{3) 4)}
4.35	Turning radius	Wa (mm)	2965 ³⁾
Performance data			
5.1	Travel speed,laden unladen	km/h	9 / 12
5.2	Lift speed,laden/unladen	mm/s	40 / 64
5.3	Lowering speed,laden/unladen	mm/s	60 / 40
5.8	Max. gradeability, laden/unladen	%	6 / 12
5.10	Service brake		Eletromagnetic
Electric-engine			
6.1	Drive motor rating S2 60min	kW	2.6
6.2	Lift motor rating at S3 10%	kW	2.2
6.3	Battery acc. to DIN 43531/35/36A,B,C,norm		No,3PzS
6.4	Battery voltage,nominal capacity K5	V / Ah	24 / 465
6.5	Battery Weight	kg	352
6.6	Energy consumption acc. to VDI cycle	kWh/h	0.7
Additional data			
8.1	Type of drive control		AC speed Control
8.4	Sound level at driver's ear acc. to EN 12053	dB(A)	<70

1)- After the fork descent x=1600mm, y=2788mm; 2)- Install crash pads l1=3810mm, l2=1409;
 3)- Install crash pads Wa=3005mm, Ast=4010mm;
 4)- According to the VDI diagonal algorithm Ast=original measurement+94mm.